



SOMMERS

SMG DP 13

MODEL:SMGDP 13

Power rating @ 60Hz		Power rating @ 50Hz	
Prime	13 KW	Prime	10.5 KW
Standby	14 KW	Standby	11.5 KW

Generator set comprising engine and alternator assembly mounted on fabricated steel profile baseframe. Baseframe is painted with a phosphate primer and top coat.

The alternator is directly coupled to the engine and the rotor is fixed to the flywheel using steel discs for flexibility. This assembly guarantees perfect alignment and the absence of vibration.

The engine is fixed to the baseframe using anti-vibration pads.

ENGINE: PERKINS (Four- stroke diesel engine with direct injection)

Model	403C15G	Aspiration	Indirect Injection
No. of cylinders	3	Cooling	Water
Engine capacity	1496c.c	Speed 60 / 50Hz	1800 / 1500 Rpm
Bore	84mm		
Stroke	90mm		
Compression Ratio	22.5:1		

Standard Single Wall Sub-base Tank: 30 Litre

Fuel Consumption

Load	I / hr	I / hr
	60Hz	50Hz
25% load	0	0
50% load	2.4	2.1
75% load	3.3	2.8
100% load	4.3	3.7

Cooling System

Closed circuit water cooled with expansion tank included in the radiator. Tropical radiator and fan with guard. Suitable for working at ambient temperatures of up to 53°C.

Air flow fan 60 / 50 Hz	1.08 / 1.23 m3/min
Cooling system capacity	5.9L

Lubrication system

Forced lubrication with gear type pump. Oil filter.

Oil sump capacity	6 L
Oil consumption	.78% Fuel Consumption

Air intake system

Turbo charged with dry air filter.

Combustion air flow 0.45 / .6 - m3min

Injection system

Linear injection pump. Fuel filter and pre-filter.

Electrical system

12 V starting system. Axial starter motor. 12 V battery 55 Amp, 55 Amp Battery charging alternator. Oil pressure and engine temperature sensors.

Protection System

Automatic engine shutdown with LED indication for low oil pressure, high engine temperature, battery charge failure, overcrank, & overspeed

Exhaust System

Consists of residential exhaust silencer with 10dB(A) noise reduction, stainless steel flexible hose and brackets. Optionally, a critical or hospital grade silencer can be supplied.

Alternator

MECC Alte SPA Brushless Alternator. Self regulated via compound voltage regulation. Windings are Class H insulated. All wound components are impregnated with polyester resin for resistance to acids and oils. Protection grade IP 22.

ELECTRICAL SYSTEM

Control Panel GPM-2

3pos. Switch (Auto/Off/Manual)	■	Three-phase terminals	■
Ammeter	1	Engine temperature gauge	■
Frequency meter	1	Fuel level gauge	■
Voltmeter	1	Battery charge meter	■
Battery voltmeter	□	Oil pressure gauge	■
Mains-generator switch	□	ON lamp	■
3-phase monitoring card	□	Heater lamp	□
Hours run meter	■	Emergency stop button	□

Breaker: 120 / 240V, 1Ph = 55Amp
 120 / 208V, 3Ph = 45Amp
 347 / 600V, 3Ph = 15Amp

Dimensions

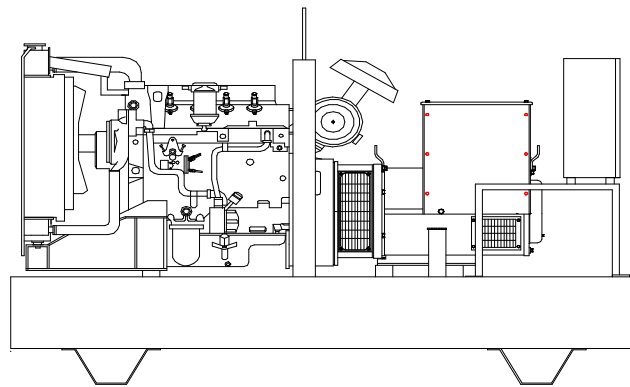
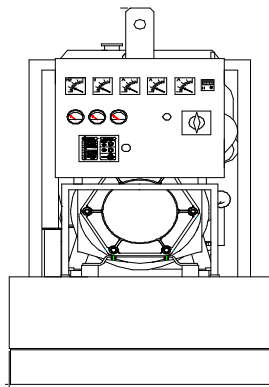

	SILENT	OPEN
Length (L)	73	55
Width (W)	33	28
Height (H)	48	43
Weight (lb')	1440	1000

NOTE: Not for
 Construction use
 Consult factory.