



SOMMERS

SMG DP 80

MODEL:SMGDP 80

Power rating @ 60Hz		Power rating @ 50Hz	
Prime	73 KW	Prime	64 KW
Standby	80 KW	Standby	70 KW

Generator set comprising engine and alternator assembly mounted on fabricated steel profile baseframe. Baseframe is painted with a phosphate primer and top coat.

The alternator is directly coupled to the engine and the rotor is fixed to the flywheel using steel discs for flexibility. This assembly guarantees perfect alignment and the absence of vibration.

The engine is fixed to the baseframe using anti-vibration pads.

ENGINE: PERKINS (Four- stroke diesel engine with direct injection)

Model	1004A-44TG2	Aspiration	Turbo charged
No. of cylinders	4	Cooling	Water cooled
Engine capacity	4.4 Litres	Speed 60 / 50Hz	1800 / 1500 rpm
Bore	105mm.	Standby Hp @ 60Hz	125 Hp
Stroke	127mm.		
Compression Ratio	17.25:1		

Standard Single Wall Sub-base Tank: 157 Litre

Fuel Consumption

Load	I / hr	I / hr
	60Hz	50Hz
25% load	6,5	5,2
50% load	11,9	9,7
75% load	16,9	14,0
100% load	22,3	18,7

Cooling System

Closed circuit water cooled with expansion tank included in the radiator. Tropical radiator and fan with guard. Suitable for working at ambient temperatures of up to 53°C.

Air flow fan 60 / 50 Hz	111/89m3min
Cooling system capacity	13.0L

Lubrication system

Forced lubrication with gear type pump. Oil filter.

Lubricating oil capacity: Total system	8.0 L
Oil consumption	Max. 0.15% of fuel consumption

SMG DP 80

Effective October 1, 2005

Air intake system

Turbo charged with dry air filter.
Combustion air flow

6.5 / 5.14m³min

Injection system

Rotary injection pump with mechanical governor. Fuel filter and pre-filter.

Electrical system

12 V starting system. Axial starter motor. 97 Ah battery, 65 Amp Battery charging alternator. Oil pressure and engine temperature sensors.

Protection System

Automatic engine shutdown with LED indication for low oil pressure, high engine temperature, battery charge failure, overcrank, & overspeed

Exhaust System

Consists of residential exhaust silencer with 10dB(A) noise reduction, stainless steel flexible hose and brackets. Optionally, a critical or hospital grade silencer can be supplied.

Alternator

Stamford / Newage Brushless Alternator. Self regulated via SX460 AVR keeping voltage within 1.5%. Windings are Class H insulated, All wound components are impregnated with polyester resin for resistance to acids and oils. Protection grade IP 22.

ELECTRICAL SYSTEM

Control Panel GPM-2

Voltmeter switch	1	Manual start up	■
Ammeter	3 (on 3Ph system only)	Remote control start up	■
Frequency meter	1	Startup failure	■
Hours run meter	■	Battery charge failure	■
Fuel level gauge	■	Low oil level	■
Water temperature gauge	■	High water temperature	■
Oil pressure gauge	□	Low fuel level	■
Battery intensity gauge	□	Water level in radiator	■
Battery voltage gauge	□	Emergency stop button (housed units only)	■
Main Line Breaker	■	Overspeeding	■
Auto start up for main failure	□	Overload	■
		Maintenance	■

Breaker: 120 / 240V, 1Ph = 350Amp
120 / 208V, 3Ph = 275Amp
347 / 600V, 3Ph = 100Amp

Dimensions

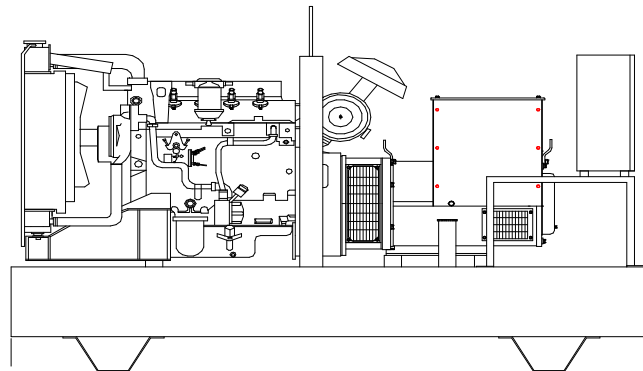
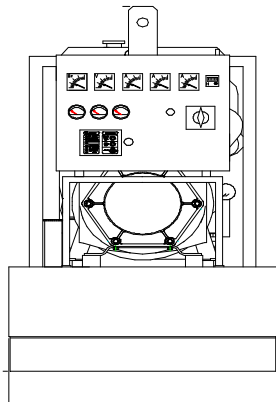

	SILENT	OPEN
Length (L)	110	81.29
Width (W)	38.58	31.49
Height (H)	60.43	68.18
Weight (lb')	3574.3	2273.35

Outlet Air Louvre 28"
Inlet Air Louvre 30"

NOTE: Not for
Construction use
Consult factory.