



# SOMMERS

## SMG DP 9

MODEL:SMGDP 9

Power rating @ 60Hz		Power rating @ 50Hz	
<b>Prime</b>	9 KW	<b>Prime</b>	7 KW
<b>Standby</b>	10 KW	<b>Standby</b>	8 KW

Generator set comprising engine and alternator assembly mounted on fabricated steel profile baseframe. Baseframe is painted with a phosphate primer and top coat.

The alternator is directly coupled to the engine and the rotor is fixed to the flywheel using steel discs for flexibility. This assembly guarantees perfect alignment and the absence of vibration.

The engine is fixed to the baseframe using anti-vibration pads.

**ENGINE: PERKINS** (Four- stroke diesel engine with direct injection)

Model	403C11G	Aspiration	Naturally aspirated
No. of cylinders	3	Cooling	Water cooled
Engine capacity	1131c.c.	Speed 60 / 50Hz	1800/1500rpm
Bore	77mm		
Stroke	81mm		
Compression Ratio	23:1		

**Standard Single Wall Sub-base Tank: 30 Litre**

### Fuel Consumption

Load	l / hr	
	60Hz	50Hz
25% load	0	0
50% load	1.8	1.5
75% load	2.4	2
100% load	3.3	2.6

### Cooling System

Closed circuit water cooled with expansion tank included in the radiator. Tropical radiator and fan with guard. Suitable for working at ambient temperatures of up to 53°C.

Air flow fan 60 / 50 Hz	.9 / .7 m <sup>3</sup> / min
Cooling system capacity	N / A

### Lubrication system

Forced lubrication with gear type pump. Oil filter.

Oil sump capacity	4.9L
Oil consumption	.77% Fuel Consumption

# SMG DP 9

Effective September 9, 2004

## Air intake system

Turbo charged with dry air filter.

Combustion air flow

40 / 35 m<sup>3</sup>m

## Injection system

Linear injection pump. Fuel filter and pre-filter.

## Electrical system

12 V starting system. Axial starter motor. 55Ah battery, 15 Amp Battery charging alternator. Oil pressure and engine temperature sensors.

## Protection System

Automatic engine shutdown with LED indication for low oil pressure, high engine temperature, battery charge failure, overcrank, & overspeed

## Exhaust System

Consists of residential exhaust silencer with 10dB(A) noise reduction, stainless steel flexible hose and brackets. Optionally, a critical or hospital grade silencer can be supplied.

## Alternator

MECC Alte SPA Brushless Alternator. Self regulated via compound voltage regulation Windings are Class H insulated, All wound components are impregnated with polyester resin for resistance to acids and oils. Protection grade IP 22.

## ELECTRICAL SYSTEM

### Control Panel GPM-2

3pos. Switch (Auto/Off/Manual) ■  
 Ammeter 1  
 Frequency meter 1  
 Voltmeter 1  
 Battery voltmeter □  
 Mains-generator switch □  
 3-phase monitoring card □  
 Hours run meter ■

Three-phase terminals ■  
 Engine temperature gauge ■  
 Fuel level gauge ■  
 Battery charge meter ■  
 Oil pressure gauge ■  
 ON lamp ■  
 Heater lamp □  
 Emergency stop button □

**Breaker:** 120 / 240V, 1Ph = 40Amp  
 120 / 208V, 3Ph = 30Amp  
 347 / 600V, 3Ph = 10Amp

## Dimensions

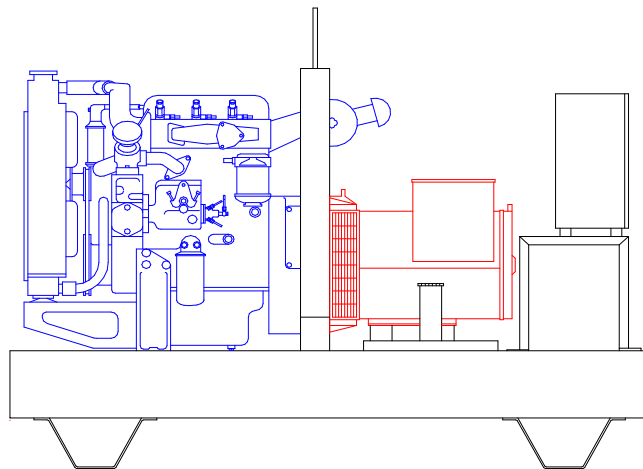
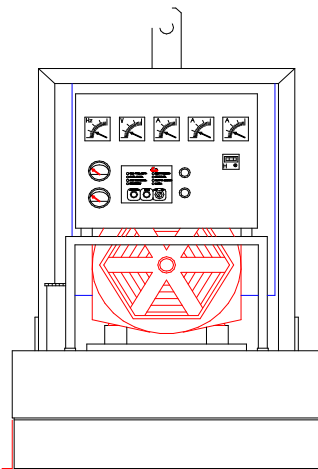

	<b>SILENT</b>	<b>OPEN</b>
Length (L)	73	55
Width (W)	33	28
Height (H)	48	43
Weight (lb's)	1206	765

NOTE: Not for  
 Construction use  
 Consult factory.