



# **SOMMERS** MOTOR GENERATOR SALES LTD.

www.sommersgen.com

## **SSG DP30**

MODEL: SSG DP30

<b>Power rating @ 60Hz</b>		<b>Power rating @ 50Hz</b>	
<b>Prime</b>	28 KW	<b>Prime</b>	24 KW
<b>Standby</b>	31 KW	<b>Standby</b>	26 KW

Generator set comprising engine and alternator assembly mounted on fabricated steel profile baseframe. Baseframe is painted with a phosphate primer and top coat.

The alternator is directly coupled to the engine and the rotor is fixed to the flywheel using steel discs for flexibility. This assembly guarantees perfect alignment and the absence of vibration.

The engine is fixed to the baseframe using anti-vibration pads.

### **ENGINE: PERKINS** (Four- stroke diesel engine with direct injection)

Model	1103C-33G3	Induction system	Naturally aspirated
No. of cylinders	3	Cooling	Water
Engine displacement	3.30 litre	Speed 60 / 50Hz	1800 / 1500 rpm
Bore	105 mm	Standby Hp @ 60Hz	49 Hp
Stroke	127 mm		
Compression ratio	19.25:1		

### **Standard Single Wall Sub-base Fuel Tank: 90 Litre**

#### **Fuel Consumption**

<b>Load</b>	<b>l / hr</b>	<b>l / hr</b>
	<b>60Hz</b>	<b>50Hz</b>
50% load	4.9	4.2
75% load	6.6	6.1
Prime 100% load	9.5	7.8
Standby 100% load	10.1	8.7

#### **Cooling System**

Closed circuit water cooled with expansion tank included in the radiator. Tropical radiator and fan with guard. Suitable for working at ambient temperatures of up to 53°C.

Air flow fan 60 / 50 Hz	70 / 53 m3/min
Cooling system capacity	10.1 L

#### **Lubrication System**

Forced lubrication with gear type pump. Oil filter.

Lubricating oil capacity: Total system	6.5 L
Oil consumption	0.5% fuel consumption

# SSG DP30

## Air Intake System

Turbo charged with dry air filter.

Aspirated air flow 60 / 50 Hz

2.57 / 2.15 m<sup>3</sup>/min

## Injection System

Linear injection pump. Fuel filter and pre-filter.

## Electrical System

12V starting system. Axial starter motor. 1 x 12V, 75 Ah battery. Battery charger alternator. Oil pressure and engine temperature sensors.

## Protection System

Automatic engine shutdown with LCD display for low oil pressure, high engine temperature, battery charge failure, overcrank and overspeed etc.

## Exhaust System

Consists of residential exhaust silencer with 20-25 dB(A) noise reduction, stainless steel flexible hose and brackets. Optionally, a critical or hospital grade silencer can be supplied.

## Alternator

Stamford / Newage Brushless Alternator. Electronic regulated via SX460 AVR keeping voltage within 1.5%. Windings are Class H insulated. All wound components are impregnated with polyester resin for resistance to acids and oils. Protection grade IP 22.

## ELECTRICAL SYSTEM

### Control Panel: Deep Sea 7310

The 7310 is an Autostart Control Module. The module is used to automatically start a generator set, upon application of a remote signal or by manual control. The module also provides indication of operational status and fault conditions, automatically shutting down the genset and indicating failures by means of an LCD display. The module features user selectable RS232 & RS485 communications, Ethernet communications, and a real time clock that provides accurate event logging. The module is DSENet compatible and includes a comprehensive list of timers and pre-configured sequences. This allows demanding industry specifications to be achieved.

### Generator Instruments

Volts, Hz, Amps, kW, kVA, cos  $\Phi$

### Engine Instruments

RPM, oil pressure, coolant temperature, hours run, charging voltage, battery volts.

**Breaker:** 120 / 240V, 1Ph = 115 Amp  
120 / 208V, 3Ph = 90 Amp  
347 / 600V, 3Ph = 30 Amp

## Dimensions

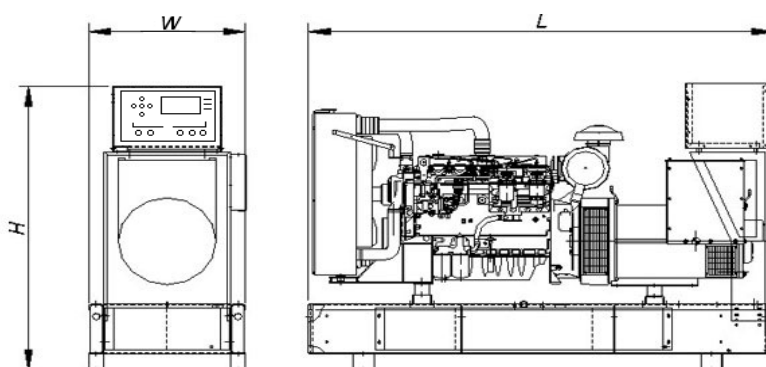

NOTE: Not for  
Construction use.  
Consult factory.

	SILENT	OPEN
Length (L)	89"	61"
Width (W)	41"	30"
Height (H)	59"	60"
Weight (lb's)	2,820	1,676

Outlet Air Louvre	20"
Inlet Air Louvre	24"