



SOMMERS MOTOR GENERATOR SALES LTD.

www.sommersgen.com

SSG DP350

MODEL: SSG DP350

Power rating @ 60Hz		Power rating @ 50Hz	
Prime	320 KW	Prime	280 KW
Standby	348 KW	Standby	320 KW

Generator set comprising engine and alternator assembly mounted on fabricated steel profile baseframe. Baseframe is painted with a phosphate primer and top coat.

The alternator is directly coupled to the engine and the rotor is fixed to the flywheel using steel discs for flexibility. This assembly guarantees perfect alignment and the absence of vibration.

The engine is fixed to the baseframe using anti-vibration pads.

ENGINE: PERKINS (Four- stroke diesel engine with direct injection)

Model	2306C-E14TAG2	Induction system	Turbocharged
No. of cylinders	6		air-to-air charge cooled
Engine displacement	14.6 litres	Cooling	Water
Bore	137 mm	Speed 60 / 50Hz	1800 / 1500 rpm
Stroke	165 mm	Standby Hp @ 60Hz	527 Hp
Compression ratio	15.9:1		

Standard Single Wall Sub-base Fuel Tank: 554 Litre

Fuel Consumption

Load	I / hr	I / hr
	60Hz	50Hz
50% load	47.0	41.0
75% load	66.0	58.0
Prime 100% load	85.0	75.0
Standby 100% load	91.0	85.0

Cooling System

Closed circuit water cooled with expansion tank included in the radiator. Tropical radiator and fan with guard. Suitable for working at ambient temperatures of up to 53°C.

Air flow fan 60 / 50 Hz	530 / 438 m ³ /min
Cooling system capacity	47.0 L

Lubrication System

Forced lubrication with gear type pump. Oil filter.

Oil capacity, Sump/total	68 L
Oil consumption	0.1% fuel consumption

SSG DP350

Air Intake System

Turbo charged with dry air filter.

Aspirated air flow 60 / 50 Hz 35 / 21.3 m³/min

Injection System

Linear injection pump. Fuel filter and pre-filter.

Electrical System

24V starting system. Axial starter motor. 2 x 12V, 120 Ah batteries. Battery charging alternator. Oil pressure and engine temperature sensors.

Protection System

Automatic engine shutdown with LCD display for low oil pressure, high engine temperature, battery charge failure, overcrank and overspeed etc.

Exhaust System

Consists of residential exhaust silencer with 20-25 dB(A) noise reduction, stainless steel flexible hose and brackets. Optionally, a critical or hospital grade silencer can be supplied.

Alternator

Stamford / Newage Brushless Alternator. Electronic regulated via SX440 AVR keeping voltage within 1.5%. Windings are Class H insulated, All wound components are impregnated with polyester resin for resistance to acids and oils. Protection grade IP 22.

ELECTRICAL SYSTEM

Control Panel: Deep Sea 7310

The 7310 is an Autostart Control Module. The module is used to automatically start a generator set, upon application of a remote signal or by manual control. The module also provides indication of operational status and fault conditions, automatically shutting down the genset and indicating failures by means of an LCD display. The module features user selectable RS232 & RS485 communications, Ethernet communications, and a real time clock that provides accurate event logging. The module is DSENet compatible and includes a comprehensive list of timers and pre-configured sequences. This allows demanding industry specifications to be achieved.

Generator Instruments

Volts, Hz, Amps, kW, kVA, cos Φ

Engine Instruments

RPM, oil pressure, coolant temperature, hours run, charging voltage, battery volts.

Breaker: 120 / 208V, 3Ph = 1225 Amp
 347 / 600V, 3Ph = 425 Amp

Dimensions

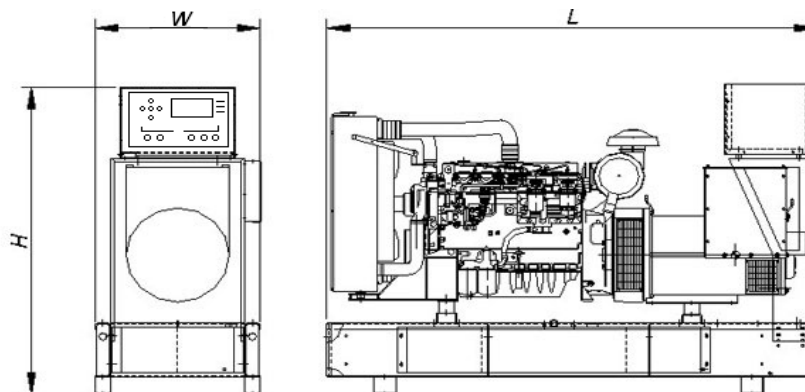

NOTE: Not for
Construction use.
Consult factory.

	SILENT	OPEN
Length (L)	180"	135"
Width (W)	60"	46"
Height (H)	88"	87"
Weight (lb's)	10,800	8,270

Outlet Air Louvre 46"W x 52"H
 Inlet Air Louvre 60"W x 60"H