

SOMMERS MOTOR GENERATOR SALES LTD.

www.sommersgen.com

SSG DP60

MODEL: SSG DP60

| Power rating @ 60Hz | | Power rating @ 50Hz | |
|---------------------|-------|---------------------|-------|
| Prime | 54 KW | Prime | 48 KW |
| Standby | 60 KW | Standby | 53 KW |

Generator set comprising engine and alternator assembly mounted on fabricated steel profile baseframe. Baseframe is painted with a phosphate primer and top coat.

The alternator is directly coupled to the engine and the rotor is fixed to the flywheel using steel discs for flexibility. This assembly guarantees perfect alignment and the absence of vibration.

The engine is fixed to the baseframe using anti-vibration pads.

ENGINE: PERKINS (Four- stroke diesel engine with direct injection)

| | | | |
|---------------------|-------------|-------------------|-----------------|
| Model | 1104C-44TG3 | Aspiration | Turbocharged |
| No. of cylinders | 4 | Cooling | Water |
| Engine displacement | 4.41 litres | Speed 60 / 50Hz | 1800 / 1500 rpm |
| Bore | 105 mm | Standby Hp @ 60Hz | 91 Hp |
| Stroke | 127 mm | | |
| Compression ratio | 18.2:1 | | |

Standard Single Wall Sub-base Fuel Tank: 157 Litre

Fuel Consumption

| Load | I / hr | I / hr |
|-------------------|--------|--------|
| | 60Hz | 50Hz |
| 50% load | 9.5 | 6.2 |
| 75% load | 12.1 | 10.2 |
| Prime 100% load | 17.7 | 15.3 |
| Standby 100% load | 19.7 | 17.2 |

Cooling System

Closed circuit water cooled with expansion tank included in the radiator. Tropical radiator and fan with guard. Suitable for working at ambient temperatures of up to 53°C.

| | |
|-------------------------|------------------|
| Air flow fan 60 / 50 Hz | 111 / 89 m3/min. |
| Cooling system capacity | 12.6 L |

Lubrication System

Forced lubrication with gear type pump. Oil filter.

| | |
|--|-----------------------|
| Lubricating oil capacity: Total system | 8.5 L |
| Oil consumption | 0.2% fuel consumption |

SSG DP60

Air Intake System

Turbo charged with dry air filter.

Aspirated air flow 60 / 50 Hz

4.9 / 3.9 m³/min

Injection System

Linear injection pump. Fuel filter and pre-filter.

Electrical System

12V starting system. Axial starter motor. 1 x 12V, 97 Ah battery. Battery charging alternator. Oil pressure and engine temperature sensors.

Protection System

Automatic engine shutdown with LCD display for low oil pressure, high engine temperature, battery charge failure, overcrank and overspeed etc.

Exhaust System

Consists of residential exhaust silencer with 20-25 dB(A) noise reduction, stainless steel flexible hose and brackets. Optionally, a critical or hospital grade silencer can be supplied.

Alternator

Stamford / Newage Brushless Alternator. Electronic regulated via SX460 AVR keeping voltage within 1.5%. Windings are Class H insulated. All wound components are impregnated with polyester resin for resistance to acids and oils. Protection grade IP 22.

ELECTRICAL SYSTEM

Control Panel: Deep Sea 7310

The 7310 is an Autostart Control Module. The module is used to automatically start a generator set, upon application of a remote signal or by manual control. The module also provides indication of operational status and fault conditions, automatically shutting down the genset and indicating failures by means of an LCD display. The module features user selectable RS232 & RS485 communications, Ethernet communications, and a real time clock that provides accurate event logging. The module is DSENet compatible and includes a comprehensive list of timers and pre-configured sequences. This allows demanding industry specifications to be achieved.

Generator Instruments

Volts, Hz, Amps, kW, kVA, cos ϕ

Engine Instruments

RPM, oil pressure, coolant temperature, hours run, charging voltage, battery volts.

Breaker 120 / 240V, 1Ph = 250 Amp
120 / 208V, 3Ph = 200 Amp
347 / 600V, 3Ph = 75 Amp

Dimensions

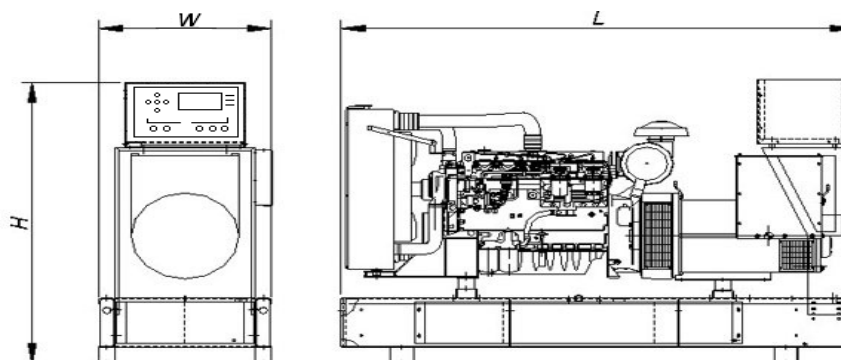

NOTE: Not for Construction use.
Consult factory.

| | SILENT | OPEN | | |
|---------------|---------------|-------------|-------------------|-----|
| Length (L) | 89" | 77" | Outlet Air Louvre | 28" |
| Width (W) | 41" | 32" | Inlet Air Louvre | 28" |
| Height (H) | 59" | 68" | | |
| Weight (lb's) | 3,381 | 2,083 | | |