

SOMMERS MOTOR GENERATOR SALES LTD.

www.sommersgen.com

SSG DP80

MODEL: SSG DP80

Power rating @ 60Hz		Power rating @ 50Hz	
Prime	72 KW	Prime	64 KW
Standby	80 KW	Standby	70 KW

Generator set comprising engine and alternator assembly mounted on fabricated steel profile baseframe. Baseframe is painted with a phosphate primer and top coat.

The alternator is directly coupled to the engine and the rotor is fixed to the flywheel using steel discs for flexibility. This assembly guarantees perfect alignment and the absence of vibration.

The engine is fixed to the baseframe using anti-vibration pads.

ENGINE: PERKINS (Four- stroke diesel engine with direct injection)

Model	1104C-44TAG1	Induction system	Turbocharged
No. of cylinders	4		air-to-air charge cooled
Engine displacement	4.41 litres	Cooling	Water
Bore	105 mm.	Speed 60 / 50Hz	1800 / 1500 rpm
Stroke	127 mm.	Standby Hp @ 60Hz	125 Hp
Compression ratio	18.2:1		

Standard Single Wall Sub-base Fuel Tank: 157 Litre

Fuel Consumption

Load	l / hr	
	60Hz	50Hz
50% load	11.7	9.8
75% load	17	14.3
Prime 100% load	22	18.6
Standby 100% load	24.1	20.3

Cooling System

Closed circuit water cooled with expansion tank included in the radiator. Tropical radiator and fan with guard. Suitable for working at ambient temperatures of up to 53°C.

Air flow fan 60 / 50 Hz	111 / 89 m3min
Cooling system capacity	12.6 L

Lubrication System

Forced lubrication with gear type pump. Oil filter.

Lubricating oil capacity: Total system	8.0 L
Oil consumption	0.15% fuel consumption

SSG DP80

Air Intake System

Turbo charged with dry air filter.

Aspirated air flow 60 / 50 Hz

6.5 / 5.14 m3/min

Injection System

Linear injection pump. Fuel filter and pre-filter.

Electrical System

12V starting system. Axial starter motor. 1 x 12V, 97 Ah battery. Battery charging alternator. Oil pressure and engine temperature sensors.

Protection System

Automatic engine shutdown with LCD display for low oil pressure, high engine temperature, battery charge failure, overcrank and overspeed etc.

Exhaust System

Consists of residential exhaust silencer with 20-25 dB(A) noise reduction, stainless steel flexible hose and brackets. Optionally, a critical or hospital grade silencer can be supplied.

Alternator

Stamford / Newage Brushless Alternator. Electronic regulated via SX460 AVR keeping voltage within 1.5%. Windings are Class H insulated. All wound components are impregnated with polyester resin for resistance to acids and oils. Protection grade IP 22.

ELECTRICAL SYSTEM

Control Panel: Deep Sea 7310

The 7310 is an Autostart Control Module. The module is used to automatically start a generator set, upon application of a remote signal or by manual control. The module also provides indication of operational status and fault conditions, automatically shutting down the genset and indicating failures by means of an LCD display. The module features user selectable RS232 & RS485 communications, Ethernet communications, and a real time clock that provides accurate event logging. The module is DSENet compatible and includes a comprehensive list of timers and pre-configured sequences. This allows demanding industry specifications to be achieved.

Generator Instruments

Volts, Hz, Amps, kW, kVA, cos Φ

Engine Instruments

RPM, oil pressure, coolant temperature, hours run, charging voltage, battery volts.

Breaker: 120 / 240V, 1Ph = 350 Amp
 120 / 208V, 3Ph = 275 Amp
 347 / 600V, 3Ph = 100 Amp

Dimensions

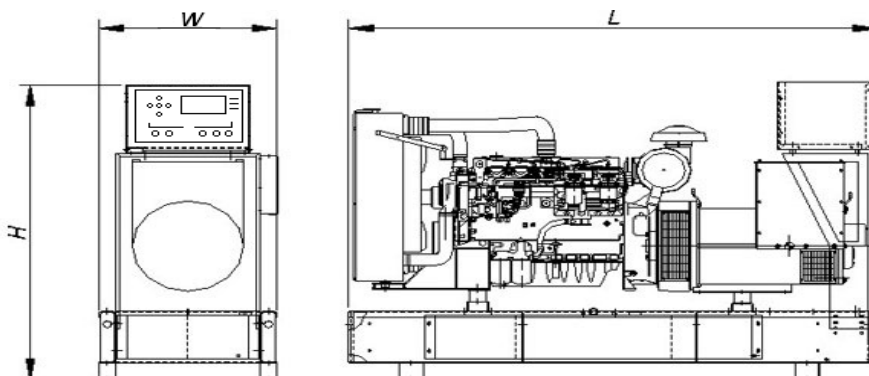

NOTE: Not for Construction use. Consult factory.

	SILENT	OPEN
Length (L)	110"	77"
Width (W)	39"	32"
Height (H)	60"	68"
Weight (lb's)	3,716	2,418

Outlet Air Louvre	28"
Inlet Air Louvre	30"