

SOMMERS MOTOR GENERATOR SALES LTD.

www.sommersgen.com

SSG DV120

MODEL: SSG DV120

Power rating @ 60Hz		Power rating @ 50Hz	
Prime	106 KW	Prime	95.4 KW
Standby	117 KW	Standby	105.3 KW

Generator set comprising engine and alternator assembly mounted on fabricated steel profile baseframe. Baseframe is painted with a phosphate primer and top coat.

The alternator is directly coupled to the engine and the rotor is fixed to the flywheel using steel discs for flexibility. This assembly guarantees perfect alignment and the absence of vibration.

The engine is fixed to the baseframe using anti-vibration pads.

ENGINE: VOLVO PENTA (Four- stroke diesel engine with direct injection)

Model	TAD523GE	Induction system	Turbocharged
No. of cylinders	4	Cooling	Water cooled
Engine displacement	4.76 litres	Speed 60 / 50 Hz	1800 / 1500 rpm
Bore	108 mm	Prime power	153 - 176 hp
Stroke	130 mm		
Compression Ratio	17.5:1		

Standard Single Wall Sub-base Fuel Tank: 264 Litres

Fuel Consumption

Load	l / hr	l / hr
	60Hz	50Hz
25% load	9	7.5
50% load	15.3	13.3
75% load	22	19.7
100% load	30.2	26.7

Cooling System

Closed circuit water cooled with expansion tank included in the radiator. Tropical radiator and fan with guard. Suitable for working at ambient temperatures of up to 53°C.

Air flow fan 60 Hz	180 m3/min
Cooling system capacity	24 L

Lubrication System

Forced lubrication with gear type pump. Oil filter.

Oil sump capacity 60 Hz	13 L
Oil consumption	0.3% fuel consumption

SSG DV120

Air Intake System

Turbo charged with dry air filter.

Combustion air flow

8.03 m³/min

Injection System

In-Line injection pump with centrifugal governor. Fuel filter and pre-filter.

Electrical System

12V starting system. Axial starter motor. 1 x 12V, 180 Ah battery. Battery charging alternator. Oil pressure and engine temperature sensors.

Protection System

Automatic engine shutdown with LCD display for low oil pressure, high engine temperature, battery charge failure, overcrank and overspeed etc.

Exhaust System

Consists of residential exhaust silencer with 20-25 dB(A) noise reduction, stainless steel flexible hose and brackets. Optionally, a critical or hospital grade silencer can be supplied.

Alternator

Stamford / Newage Brushless Alternator. Electronic regulated via SX460 AVR keeping voltage within 1.5%. Windings are Class H insulated. All wound components are impregnated with polyester resin for resistance to acids and oils. Protection grade IP 22.

ELECTRICAL SYSTEM

Control Panel: Deep Sea 7310

The 7310 is an Autostart Control Module. The module is used to automatically start a generator set, upon application of a remote signal or by manual control. The module also provides indication of operational status and fault conditions, automatically shutting down the genset and indicating failures by means of an LCD display. The module features user selectable RS232 & RS485 communications, Ethernet communications, and a real time clock that provides accurate event logging. The module is DSENet compatible and includes a comprehensive list of timers and pre-configured sequences. This allows demanding industry specifications to be achieved.

Generator Instruments

Volts, Hz, Amps, kW, kVA, cos Φ

Engine Instruments

RPM, oil pressure, coolant temperature, hours run, charging voltage, battery volts.

Dimensions

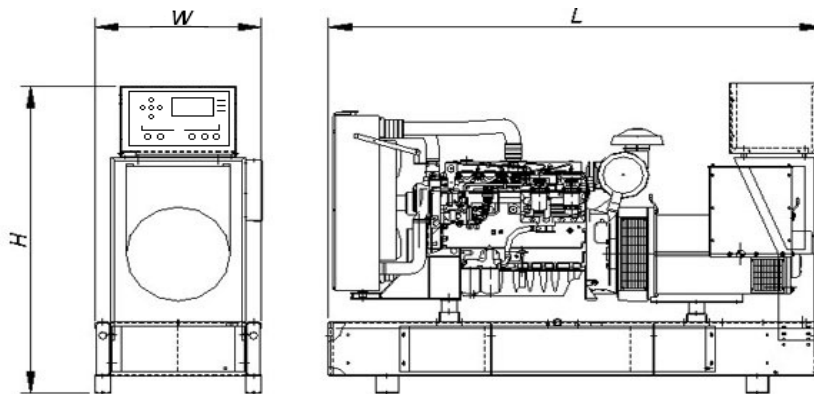

NOTE: Not for
Construction use.
Consult factory.

	SILENT	OPEN
Length (L)	134"	98"
Width (W)	43"	33"
Height (H)	69"	74"
Weight (lb's)	5,057	3,298