



# SOMMERS MOTOR GENERATOR SALES LTD.

www.sommersgen.com

## SSG DV400

MODEL: SSG DV400

Power rating @ 60Hz		Power rating @ 50Hz	
<b>Prime</b>	364 KW	<b>Prime</b>	320 KW
<b>Standby</b>	400 KW	<b>Standby</b>	360 KW

Generator set comprising engine and alternator assembly mounted on fabricated steel profile baseframe. Baseframe is painted with a phosphate primer and top coat.

The alternator is directly coupled to the engine and the rotor is fixed to the flywheel using steel discs for flexibility. This assembly guarantees perfect alignment and the absence of vibration.

The engine is fixed to the baseframe using anti-vibration pads.

### ENGINE: VOLVO PENTA (Four- stroke diesel engine with direct injection)

Model	TAD1242GE	Induction system	Turbocharged
No. of cylinders	6	Cooling	Water cooled
Engine displacement	12.1 L	Speed 50 / 60Hz	1500 / 1800 rpm
Bore	131 mm	Standby/Primepower 60Hz	585 / 532 Bhp
Stroke	150 mm		
Compression Ratio	17.5:1		

### Standard Single Wall Sub-base Fuel Tank: 554 Litres

#### Fuel Consumption

Load	I / hr	I / hr
	60Hz	50Hz
25% load	22	19
50% load	42	38
75% load	63	56
100% load	86	77

#### Cooling System

Closed circuit water cooled with expansion tank included in the radiator. Tropical radiator and fan with guard. Suitable for working at ambient temperatures of up to 53°C.

Fan Air Flow 60Hz	435 m <sup>3</sup> /min
Cooling System Capacity	45 L
Heat Rejection to Coolant	7905 Btu/min (prime power) 8132 Btu/min (standby)

#### Lubrication System

Forced lubrication with gear type pump. Oil filter.

Oil sump capacity	31 L
Oil consumption	0.18% fuel consumption

# SSG DV400

## Air Intake System

Turbo charged with dry air filter.

Combustion air flow 60 Hz 30 m3/min

## Injection System

Electronic Unit Injectors with EDCIII electronic governor controller. Fuel filter and pre-filter.

## Electrical System

24V starting system. Axial starter motor. 2 x 12V, 140 Ah batteries. Battery charging alternator. Oil pressure and engine temperature sensors.

## Protection System

Automatic engine shutdown with LCD display for low oil pressure, high engine temperature, battery charge failure, overcrank and overspeed etc.

## Exhaust System

Consists of residential exhaust silencer with 20-25 dB(A) noise reduction, stainless steel flexible hose and brackets. Optionally, a critical or hospital grade silencer can be supplied.

## Alternator

Stamford / Newage Brushless Alternator. Electronic regulated via AS440 AVR keeping voltage within 1.5%. Windings are Class H insulated. All wound components are impregnated with polyester resin for resistance to acids and oils. Protection grade IP 22.

## ELECTRICAL SYSTEM

### Control Panel: Deep Sea 7310

The 7310 is an Autostart Control Module. The module is used to automatically start a generator set, upon application of a remote signal or by manual control. The module also provides indication of operational status and fault conditions, automatically shutting down the genset and indicating failures by means of an LCD display. The module features user selectable RS232 & RS485 communications, Ethernet communications, and a real time clock that provides accurate event logging. The module is DSENet compatible and includes a comprehensive list of timers and pre-configured sequences. This allows demanding industry specifications to be achieved.

### Generator Instruments

Volts, Hz, Amps, kW, kVA, cos  $\Phi$

### Engine Instruments

RPM, oil pressure, coolant temperature, hours run, charging voltage, battery volts.

## Dimensions

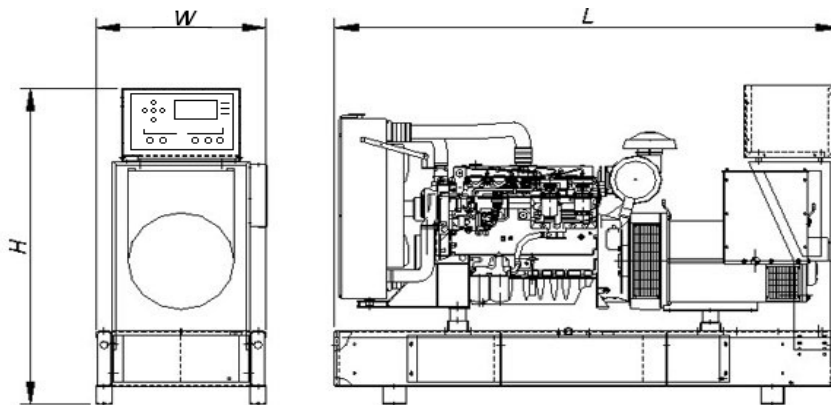

NOTE: Not for Construction use. Consult factory.

	SILENT	OPEN
Length (L)	180"	135"
Width (W)	59"	45"
Height (H)	88"	87"
Weight (Lbs)	10,890	8,360